

Z-EFG-100

Electric 2-Fingers Parallel Gripper

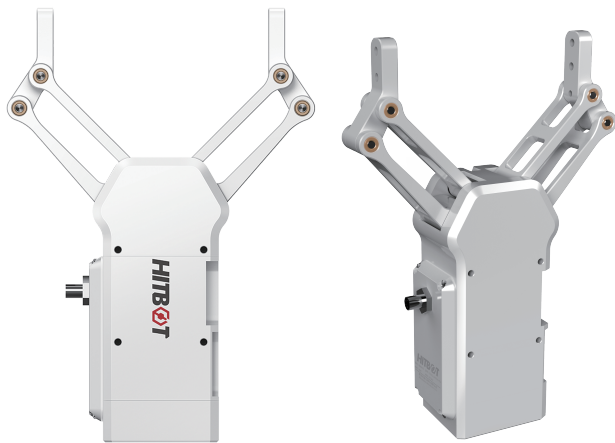

Product Features

- Large stroke
- EIA485 bus control
- Simple adaptation to robot arm

Promoting a revolution in the replacement of pneumatic grippers by electric grippers

First electric gripper with integrated servo system in China

Highly Integrated

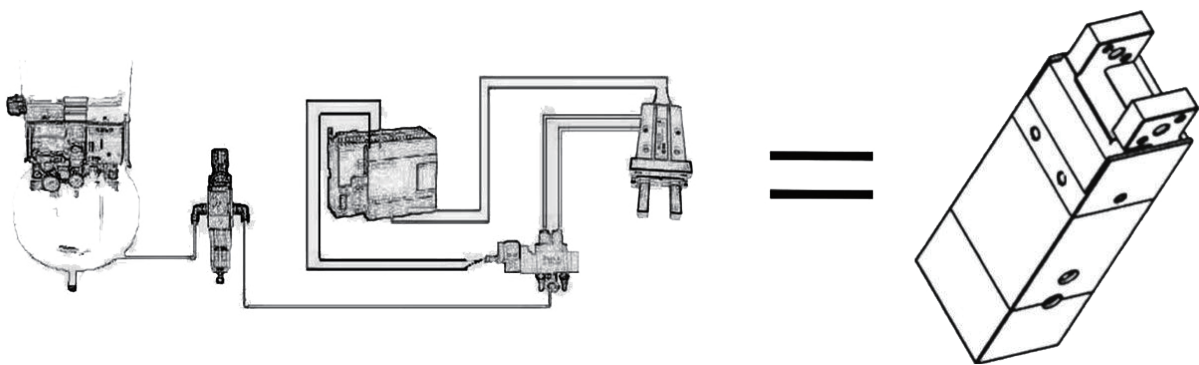

- Perfect replacement for air compressor + filter + solenoid valve + throttle valve + pneumatic gripper
- Multiple cycles service life, consistent with the traditional Japanese cylinder

Application Scenes

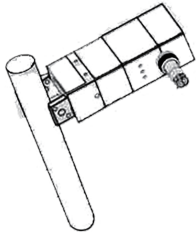

Fragile scene (e.g. test tube)

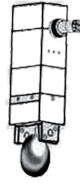

Fragile scene (e.g. eggs)

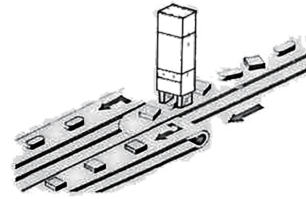

Sorting out things that are arranged in a mess

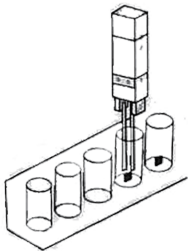

Gripping in narrow scene



Deformable scene (e.g. rings)



Gripping fragile items at high frequency



Apply for scenes without air source (e.g. laboratory, hospital)

Specification Parameters

Model No. Z-EFG-100	Parameter
Total stroke	90mm
Gripping force	35-60N
Repeatability	±0.02mm
Recommended gripping weight	0.5kg
Transmission mode	Screw nut + linkage
Grease replenishment of moving components	Every six months or 1 million movements / time
One-way stroke motion time	1s
Operating temperature range	5-55°C
Operating humidity range	RH35-80 (No frost)
Movement mode	Linkage
Stroke control	Adjustable
Clamping force adjustment	Adjustable
Weight	0.925kg
Dimensions (L*W*H)	203*144*45mm (open) 222*64*45m (close)
Controller placement	Built-in
Power	30W
Motor type	DC brushless
Rated voltage	24V
Peak Current	1.5A

Dimension Installation Diagram

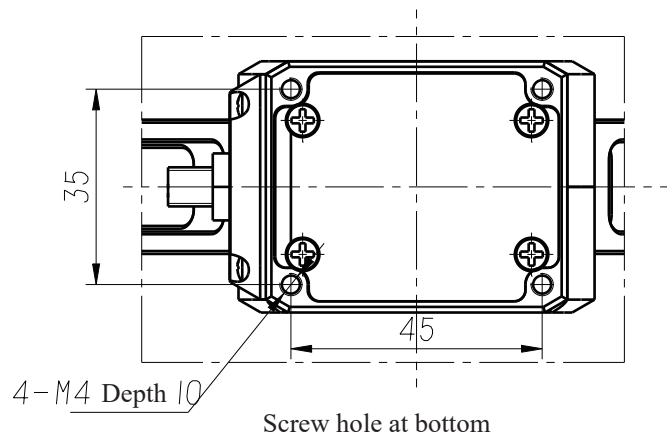
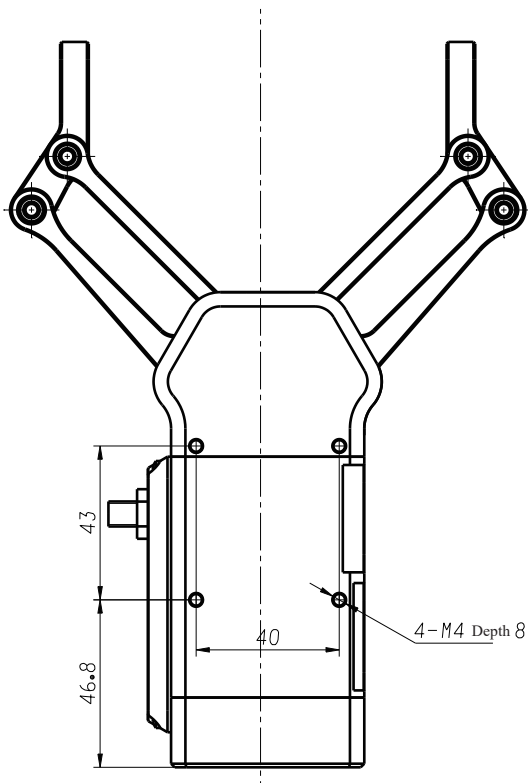
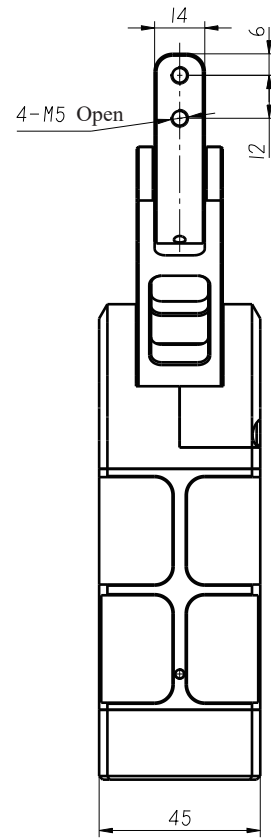
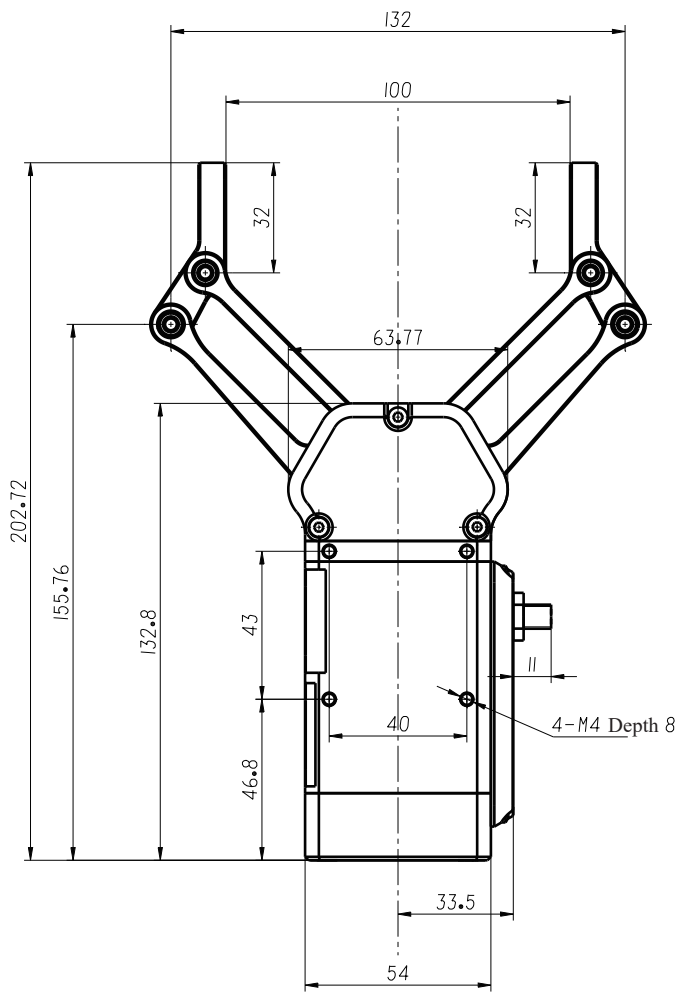

Wiring

Z-EFG-100 uses 4-core M8 aviation plug for external connection. The matching wiring could choose 180 outlet mode and 90 outlet mode. When choosing 90 outlet mode, the outlet direction is the end of the gripper (without fixture) .

Brown	24V+
Blue	0V (24V-, GND)
White	TIA/EIA-485-
Black	TIA/EIA-485+

Note:

1. Please make sure that the positive and negative polarity of the power cable is correct when wiring, and that the 485 communication wire is correct with the power cable, as the wiring error leads to burning is not within the normal warranty.
2. EIA485 and 24V grippers are not isolated internally, if isolation is needed, customers need to use other equipment for isolation.

Communication Protocols

The communication protocol adopts half-duplex mode, that is, the host computer/PLC sends control commands to the slave computer, and the slave computer returns the commands to the host computer after a period of time (configurable). The communication supports bus control, and different ID numbers can be configured for the grippers with an ID range of 0x00~0xFE. 0xFF is a broadcast command, all grippers will respond, but no command will be returned.

The host computer sends read/write commands to the grippers with the following structure:

Data head fixed length 3byte			ID 1byte	Read/Write	Start address 1byte	Data (len byte1) (write)	CRC8 1byte
0x48	0x49	0x74	0~0xFF	0x00 read/ 0x01 write	(0x00~0xFF)	0x00 ~ 0xFF	CRC-8

The structure of the write command returned by the gripper to the host computer is as follows:

Data head fixed length 3byte			ID 1byte	Status	CRC8 1byte	
0x46	0x4A	0x48	0~0xFF	CRC8 1byte	/	CRC8 1byte

Status is the status of register 0x6C, indicating the current err status

The structure of the read command returned by the gripper to the host computer is as follows:

Data head fixed length 3byte			ID 1byte	Start address 1byte	Data len 1byte	Data (len byte)	CRC8 1byte
0x46	0x4A	0x48	0~0xFF	(0x00~0xFF)	(0x00~0xFF)	0x00~0xFF	CRC-8

CRC-8 is the data checksum of the entire paragraph, starting from the data head, the host computer starts from 0x48, and the gripper return command starts from 0x46.

The CRC-8 checksum polynomial is $x^8 + x^2 + x + 1$, no reverse XOR

Reference code available :

```

#define CRC8_INIT 0
#define XOROUT 0
#define CRC8_POLY 0X07
/**
 * brief CRC8_Calc
 * param p_data* not change when run this fun
 * len <255
 * retval CRC-8
 */
U8 CRC8_Calc(U8 *p_data, U8 len)
{
    U16 window;
    U8 i,j, *crc8_h, *crc8_l;
    crc8_h = (U8*)&window+1;
    crc8_l = (U8*)&window;
    *crc8_h = CRC8_INIT;
    for(j=0; j<=len; j++)
    {
        if(j < len)
        {
            *crc8_l = *p_data;
        }
        p_data++;
        for(i=0; i<8 ;i++)
        {
            if((*crc8_h & 0x80) != 0)
            {
                //xor
                window <<= 1;
                *crc8_h ^= CRC8_POLY;
            }
            else
            {
                window <<= 1;
            }
        }
    }
    return ((*crc8_h)^XOROUT);
}
    
```

Register Address and Description

Address 0x00~Address 0x55 are the EEPROM backup addresses, which are read into RAM by EEPROM each time the power is turned on. Modifying these values will not affect the EEPROM. If the modified value is written to the EEPROM by instructions, the next power-up will read the modified value from the EEPROM.

Address	Name	R/W	Reset value	Description
0x00	ID	R/W	0x01	0x00~0xFE, 0xFF is the broadcast address
0x01	baudrate	R/W	BaudRate_1000000	0:BaudRate_1000000 1:BaudRate_500000 2:BaudRate_115200 3:BaudRate_57600 4:BaudRate_38400 5:BaudRate_9600 Other: BaudRate_9600
0x02	version_L	R	0	
0x03	version_H	R	0	
0x04	time delay_L	R/W	0x00	485 communication return delay "0" to the maximum return speed, the unit is us
0x05	time delay_H	R/W		
0x06	mode1 positon_L	R/W	0x1F4(500)	(100-1000) Setting position
0x07	mode1 positon_H	R/W		
0x08	mode1 speed	R/W	0xFF	(0-0xFF) Slowest to fastest
0x09	mode1 torque	R/W	0xFF	(0-0xFF) Minimum to maximum force
0x0A	mode1 feedback_positon_min_L	R/W	0x1C2(450)	(100-1000) Range detection small value when stopped
0x0B	mode1 feedback_positon_min_H	R/W		
0x0C	mode1 feedback_positon_max_L	R/W	0x266(550)	(100-1000) Range detection large value when stopped
0x0D	mode1 feedback_positon_max_H	R/W		
0x0E	mode2 positon_L	R/W	Repeat mode1 below	
0x0F	mode2 positon_H	R/W		
0x10	mode2 speed	R/W		
0x11	mode2 torque	R/W		
0x12	mode2 feedback_positon_min_L	R/W		
0x13	mode2 feedback_positon_min_H	R/W		
0x14	mode2 feedback_positon_max_L	R/W		
0x15	mode2 feedback_positon_max_H	R/W		

0x16	mode3 positon_L	R/W		
0x17	mode3 positon_H	R/W		
0x18	mode3 speed	R/W		
0x19	mode3 torque	R/W		
0x1A	mode3 feedback_positon_min_L	R/W		
0x1B	mode3 feedback_positon_min_H	R/W		
0x1C	mode3 feedback_positon_max_L	R/W		
0x1D	mode3 feedback_positon_max_H	R/W		
0x1E	mode4 positon_L	R/W		
0x1F	mode4 positon_H	R/W		
0x20	mode4 speed	R/W		
0x21	mode4 torque	R/W		
0x22	mode4 feedback_positon_min_L	R/W		
0x23	mode4 feedback_positon_min_H	R/W		
0x24	mode4 feedback_positon_max_L	R/W		
0x25	mode4 feedback_positon_max_H	R/W		
0x26	mode5 positon_L	R/W		
0x27	mode5 positon_H	R/W		
0x28	mode5 speed	R/W		
0x29	mode5 torque	R/W		
0x2A	mode5 feedback_positon_min_L	R/W		
0x2B	mode5 feedback_positon_min_H	R/W		
0x2C	mode5 feedback_positon_max_L	R/W		
0x2D	mode5 feedback_positon_max_H	R/W		
0x2E	mode6 positon_L	R/W		
0x2F	mode6 positon_H	R/W		
0x30	mode6 speed	R/W		
0x31	mode6 torque	R/W		
0x32	mode6 feedback_positon_min_L	R/W		
0x33	mode6 feedback_positon_min_H	R/W		

0x34	mode6 feedback_positon_max_L	R/W		
0x35	mode6 feedback_positon_max_H	R/W		
0x36	mode7 positon_L	R/W		
0x37	mode7 positon_H	R/W		
0x38	mode7 speed	R/W		
0x39	mode7 torque	R/W		
0x3A	mode7 feedback_positon_min_L	R/W		
0x3B	mode7 feedback_positon_min_H	R/W		
0x3C	mode7 feedback_positon_max_L	R/W		
0x3D	mode7 feedback_positon_max_H	R/W		
0x3E	mode8 positon_L	R/W		
0x3F	mode8 positon_H	R/W		
0x40	mode8 speed	R/W		
0x41	mode8 torque	R/W		
0x42	mode8 feedback_positon_min_L	R/W		
0x43	mode8 feedback_positon_min_H	R/W		
0x44	mode8 feedback_positon_max_L	R/W		
0x45	mode8 feedback_positon_max_H	R/W		
0x46	mode9 positon_L	R/W		
0x47	mode9 positon_H	R/W		
0x48	mode9 speed	R/W		
0x49	mode9 torque	R/W		
0x4A	mode9 feedback_positon_min_L	R/W		
0x4B	mode9 feedback_positon_min_H	R/W		
0x4C	mode9 feedback_positon_max_L	R/W		
0x4D	mode9 feedback_positon_max_H	R/W		
0x4E	mode10 positon_L	R/W		
0x4F	mode10 positon_H	R/W		
0x50	mode10 speed	R/W		
0x51	mode10 torque	R/W		

0x52	mode10 feedback_positon_min_L	R/W		
0x53	mode10 feedback_positon_min_H	R/W		
0x52	mode10 feedback_positon_max_L	R/W		
0x53	mode10 feedback_positon_max_H	R/W		
0x54	mode10 feedback_positon_max_L	R/W		
0x55	mode10 feedback_positon_max_H	R/W		

Address 0x60~address 0xA3 running register, stored in RAM and lost if power off

Address	Name	R/W	Reset value	Description
0x60	mode0 positon_L	R/W	Mode 0 is the current running status format as mode1	
0x61	mode0 positon_H	R/W		
0x62	mode0 speed	R/W		
0x63	mode0 torque	R/W		
0x64	mode0 feedback_positon_min_L	R/W		
0x65	mode0 feedback_positon_min_H	R/W		
0x66	mode0 feedback_positon_max_L	R/W		
0x67	mode0 feedback_positon_max_H	R/W		
0x68	run mode x	R/W	Run mode x, if x!=0 load to mode 0	
0x69	feedback	R	0xFF feedback state, the gripper is stopped and the position is not within the set feedback position 0xF0 feedback state, the gripper is stopped and the position is within the set feedback position 0x0F feedback state, the gripper is in motion and the position is not within the set feedback position 0x0 feedback state, the gripper is in motion and the position is within the set feedback position	
0x6A	now positon_L	R/W	Gripper current position	
0x6B	now positon_H	R/W		
0x6C	error	R	Error status feedback	error: bit7 EEPORM ERR error: bit6 Voltage ERR error: bit1 Not calibrated after power-on error: bit0 if within the feedback range

0x6D	voltage	R	Current voltage value	
0xA0	power on gripper check	R/W	Power-on calibration trigger, after power-on again, assign 0x55 open calibration, 0xAA close calibration, perform one action for once only after power-on	To prevent erroneous operations, currently only register operations are allowed
0xA1	EEPROM Rest	R/W	0xA5 write three consecutive EEPROM resets	To prevent erroneous operations, currently only register operations are allowed
0xA2	Write EEPROM	R/W	0xA5 write three consecutive 0x00~0x55, write EEPROM	To prevent erroneous operations, currently only register operations are allowed
0xA3	soft restart	R/W	0xA5 write three consecutive software resets	To prevent erroneous operations, currently only register operations are allowed

Note: The gripper will only move normally after operate the A0 register to trigger calibration each time the power is turned on.

Examples of gripper command:

Query ID: 0x48 0x49 0x74 0xff 0x00 0x00 0x01 (0x78)

Closed calibration: 0x48 0x49 0x74 0x01 0x01 0xA0 0x01 0xAA (0x35)

Open calibration: 0x48 0x49 0x74 0x01 0x01 0xA0 0x01 0x55 (0xC6)

Query voltage: 0x48 0x49 0x74 0x01 0x00 0x6D 0x01 (0xA3)

Strong & High-speed opening: 0x48 0x49 0x74 0x01 0x01 0x60 0x09 0xE8 0x03 0xff 0xff 0x00 0x00 0xFF 0x00 0x00 (0x2A)

Strong & High speed closing: 0x48 0x49 0x74 0x01 0x01 0x60 0x09 0x64 0x00 0xff 0xff 0x00 0x00 0xFF 0x00 0x00 (0x09)

Read current position: 0x48 0x49 0x74 0x01 0x00 0x6A 0x02 (0xC1)

The checksum is in parentheses